

Maintenance Kit Type 270 REPLACEMENT GUIDE < G719-8610 >

The maintenance kit contains the parts required to maintain the printer. If "Replace Maintenance Kit" appears on the panel display, install the replacement parts included in the maintenance kit. Read this guide carefully before you use the maintenance kit. For safety purposes, carefully follow the instructions in this guide.

CAUTION

- The inside of the machine becomes very hot. Do not touch the parts with a label indicating a "hot surface". Touching a "hot surface" could result in a burn injury.
- Disposal should take place at an authorized dealer or appropriate collection site.
- If you dispose of the used parts yourself, dispose of them according to local regulations.

1

TURNING OFF THE PRINTER

Turn off the printer.

Caution

- The inside of the printer becomes very hot. You must turn off the printer before attempting to replace any of the parts. When replacing the old fusing unit with a new one, turn off the printer and wait for about 60 minutes before starting the installation.

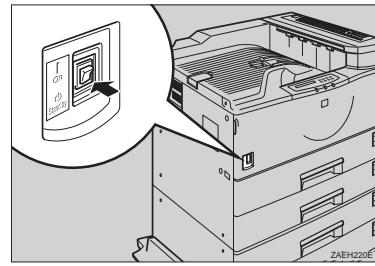

2

CHECKING THE CONTENTS OF THE BOX

Confirm that the box contains the following items.

Fusing Unit

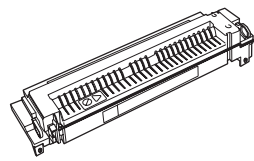

Transfer Roller

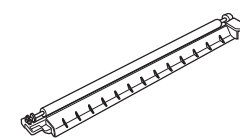

Paper Feed Rollers (4 pairs)

If the optional PS400 or PS440 is not installed, only two parts are need to be replaced.

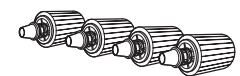

Paper Feed Rollers (3 pairs) with Stoppers (2 pairs) for PS420

If the optional PS420 is installed, these parts need to be replaced.

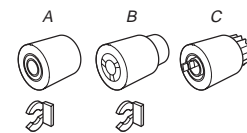

Friction Pads (4 pairs)

Two white friction pads (A) are used for the printer, two brown friction pads (B) are used for the optional PS400 or PS440.

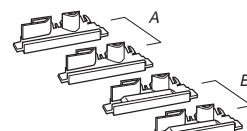

If any of the items is missing, please contact your sales or service representative.

You should replace all of the parts included in the maintenance kit at the same time. Replace them in the following order.

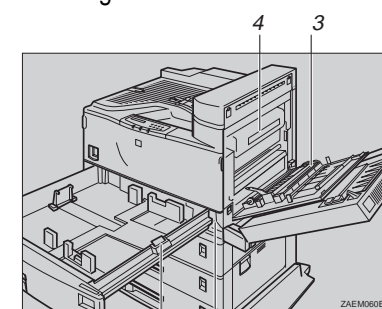

- Paper Feed Roller
- Friction Pad
- Transfer Roller
- Fusing Unit

If the optional PS420 is installed, the paper feed roller for PS420 are need to be replaced.

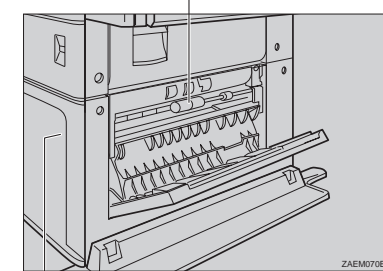

- Paper Feed Roller A for PS420
- Paper Feed Roller B,C for PS420

3

REPLACING THE PAPER FEED ROLLERS AND FRICTION PADS

Follow these steps to replace the paper feed rollers and the friction pads, of PS400 and PS440 paper trays. For information on replacing the paper feed rollers for PS420, see "REPLACING THE PAPER FEED ROLLERS FOR PS420".

1 Slide the paper tray out until it stops. Raise the front end slightly and pull the tray forward to remove it from the machine.

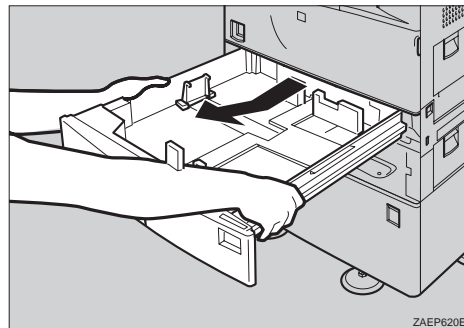

2 Confirm the position of the paper feed rollers inside of the printer.

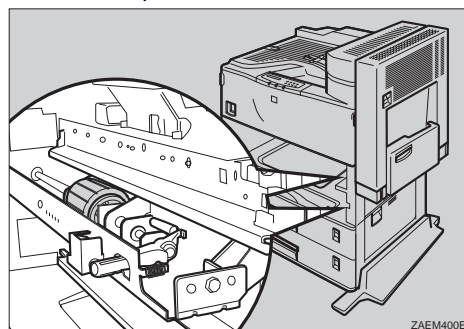

3 Pull the small green lever inside the printer on the lower right side.

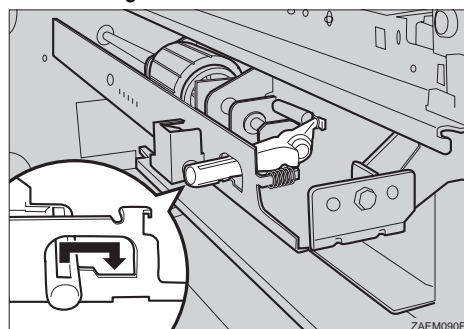

4 There is a paper feed roller on the lower right side inside of the printer. Push the paper feed roller (the paper feed roller of the paper tray that is second from the top) towards you (1), then pull it in a diagonally downward direction (2) and remove it.

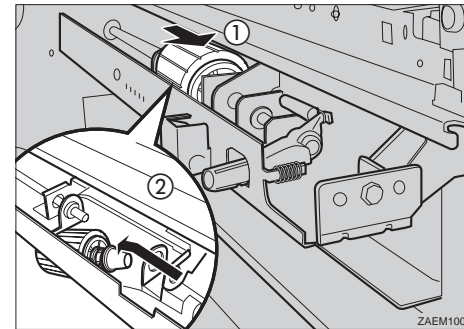

5 Take the new paper feed roller from the box and remove the plastic bag.

6 Insert the projection of the paper feed roller into the hole. While pushing the roller (1), insert the roller into the rear shaft (2).

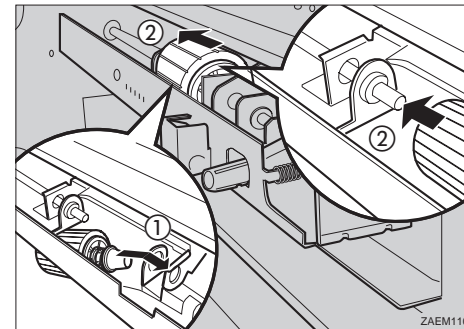

7 Check the motion of the paper feed roller to confirm that it is properly set.

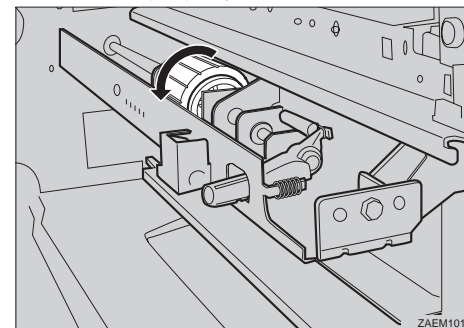

8 Return the green lever to its original position.

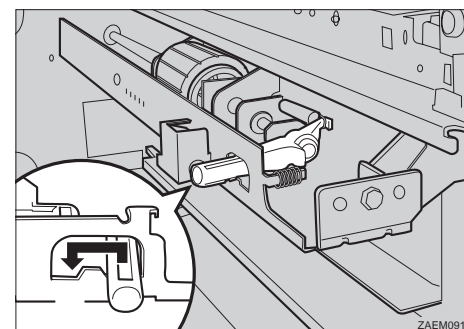

9 Replace the paper feed roller located on the upper right side inside of the printer (the paper feed roller of the top paper tray), following the steps 3 to 8.

10 Hold the both sides of the black friction pad, pull it upwards and remove it. The friction pad is on the right side of the paper tray (the second tray from the top that was) pulled out in step 1.

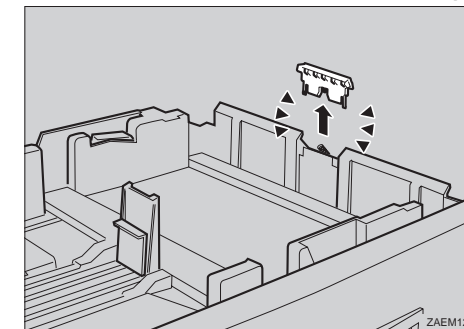

11 The new friction pad (A) has a white pad. Take it from the box and remove the plastic bag.

Important

- Do not touch the upper (white) part of the pad.

12 Hold the both sides of the friction pad with one hand. While holding the film in place with a finger of the other hand, set the friction pad into the tray so that the projection of the friction pad can be set into the spring.

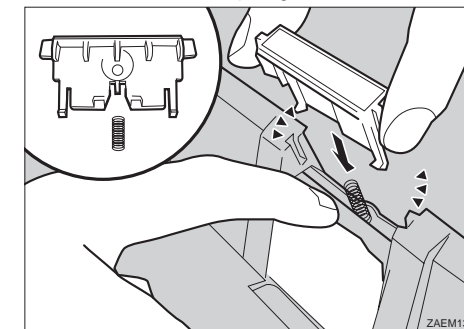

13 Confirm that the friction pad is properly set as shown in the illustration. If it is not properly set, reset the friction pad, following steps 10 to 12.

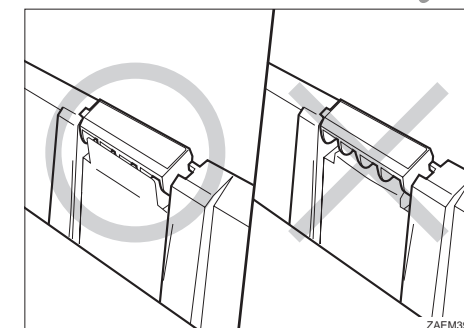

14 Replace the friction pad of the paper tray that is second from the top, following steps 10 to 13.

15 Hold the paper tray with both hands and slide it all the way into the printer. The tray with a lever and paper size dial should be second from the top.

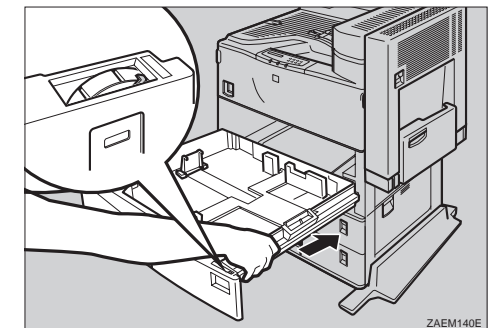

16 Slide the other tray all the way into the printer.

17 If PS400 or PS440 are installed, replace the paper feed rollers and the friction pad (B), following steps 1 to 16.

Replacing the paper feed rollers: steps 2 to 9

Replacing the friction pads: steps 10 to 13

Note

- The friction pad for PS400 or PS440 has a brown pad.

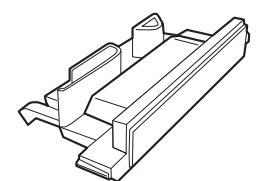

Transfer roller replacement is now finished.

4

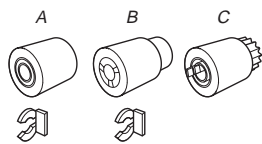

REPLACING THE PAPER FEED ROLLERS FOR PS420

This section describes how to replace the paper feed rollers for PS420. If PS420 is not installed, go to step 5.

1 Open the right cover of PS420.

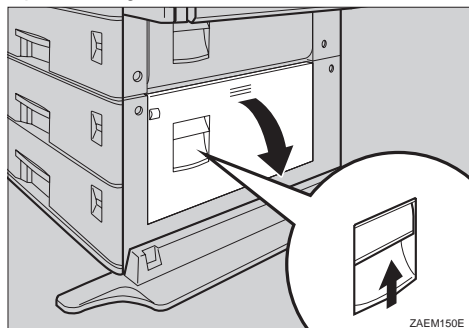

2 Open the black guide plate.

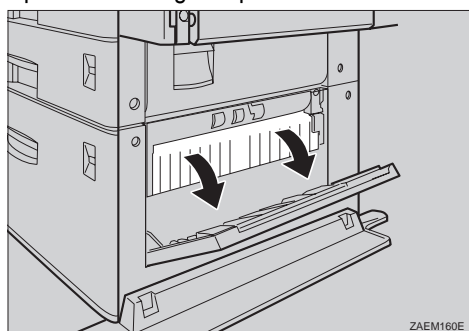

3 Pull out the paper tray with both hands. While holding the release plate panel on both sides of the tray (1), remove the paper tray from the rail (2).

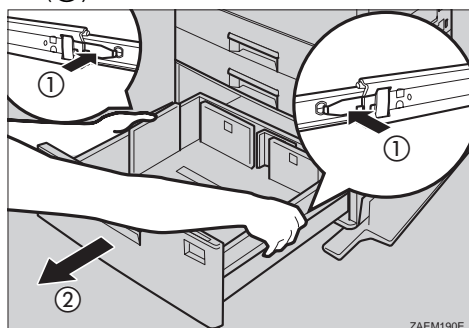

4 Remove the stopper from the paper feed roller (1), and pull out the paper feed roller (2).

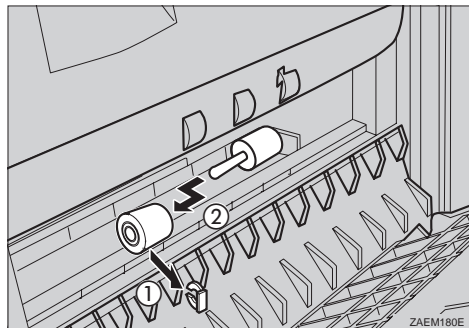

5 Remove the plastic bag from the paper feed roller and stopper for PS420 (A).

6 Hold the paper feed roller with its gear facing right and insert the roller into the shaft so that the roller gear can be meshed with the shaft gear (1), and lock it with the stopper (2).

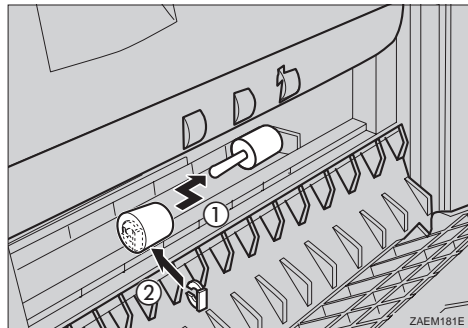

7 While pushing the pin of the front paper feed roller outwards (1), remove the paper feed roller (2).

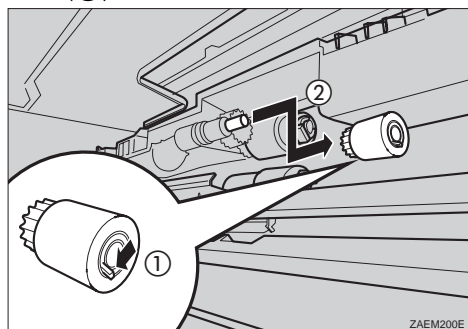

8 Remove the stopper from the rear paper feed roller (1), and remove the paper feed roller (2).

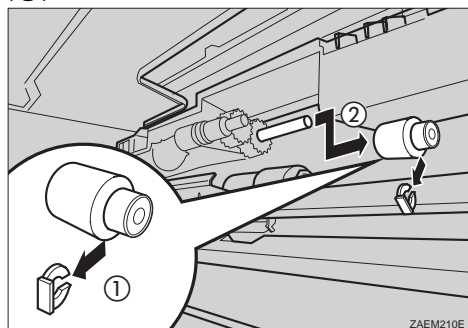

9 Remove the plastic bag from the new paper feed rollers (B)(C) for PS420.

10 Hold the new paper feed roller (B) with its gear towards the shaft. Insert it into the rear shaft so that the roller gear is meshed with the shaft gear (1). Lock the roller with the stopper (2).

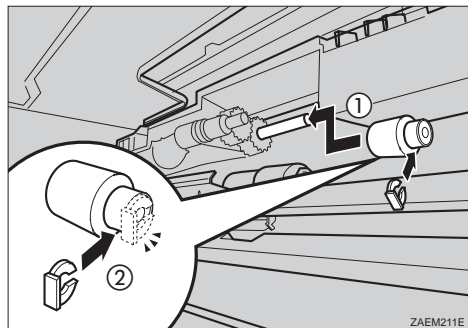

11 Hold the new paper feed roller (C), with its pin towards you (1). Insert the roller onto the front shaft until it clicks into place (2).

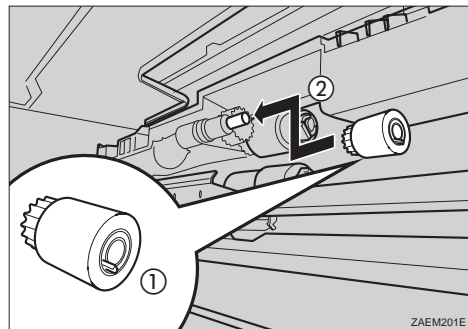

12 Hold the paper tray with both hands. Keep the tray horizontal. Align the paper tray rail onto the rail of the printer and push the tray into the printer until it stops.

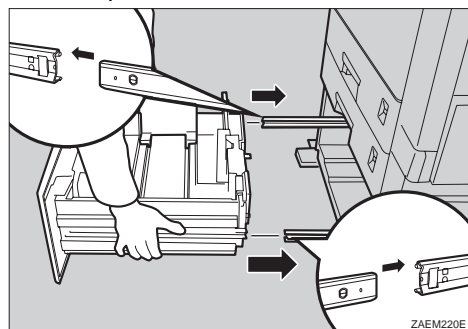

13 Close the back guide plate.

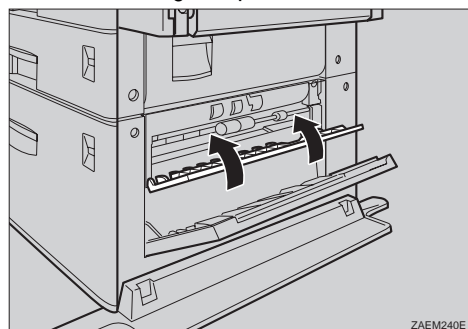

14 Close the right cover of PS420.

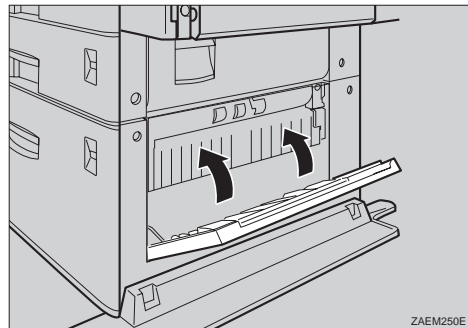

PS420 paper roller replacement is now finished.

Friction pads are not included in PS420.

5

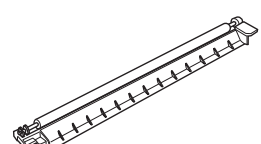

REPLACING THE TRANSFER ROLLER

1 If the duplex unit is installed, open the duplex unit by lifting the catch.

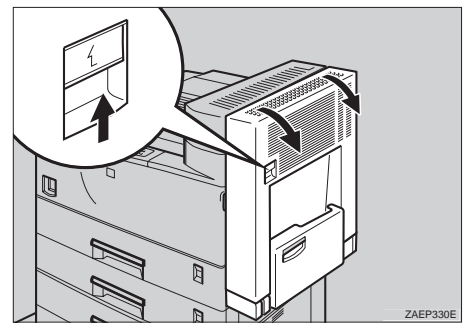

2 Open the right cover of the printer by lifting the catch.

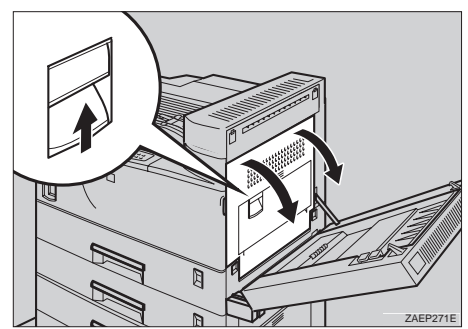

3 Hold the green catches of the transfer roller with both hands (1). Raise them to release the transfer unit (2).

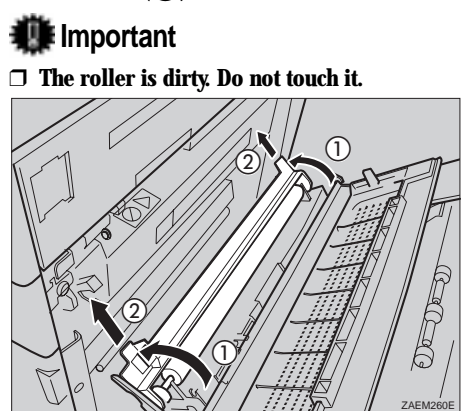

4 Take the new transfer roller from the box and remove the plastic bag.

Important

Do not touch the roller.

5 Hold the green catches of the transfer roller with both hands. Push the transfer roller until it clicks into place (1). Then, tilt it towards the cover (2).

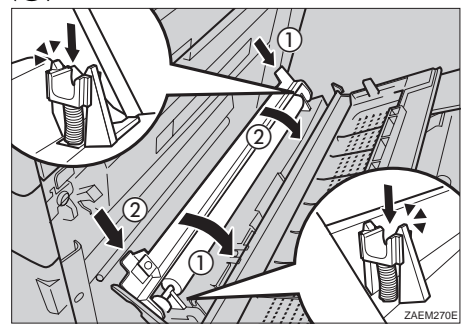

6 Put the transfer roller that was removed in step 3 into the plastic bag emptied in step 4.

Transfer roller replacement is now finished.

While opening the right cover of the printer, replace the fusing unit.

6

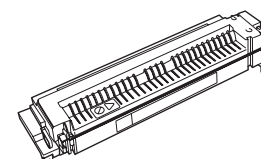

REPLACING THE FUSING UNIT

Caution

The inside of the machine becomes very hot. Turn off the printer before attempting to replace any of the parts. When replacing the old fusing unit with a new one, turn off the printer and wait for about 60 minutes before beginning the installation.

1 Turn off the printer and wait 60 minutes for the machine to cool down.

2 Use a coin to loosen the two screws holding the fusing unit.

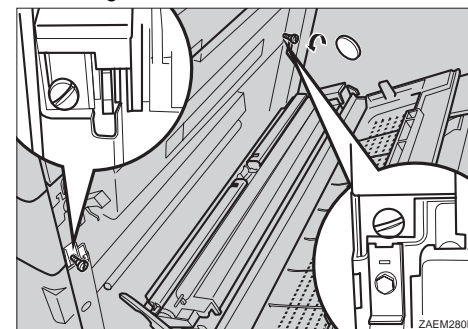

3 Hold the green catches with both hands and remove the fusing unit.

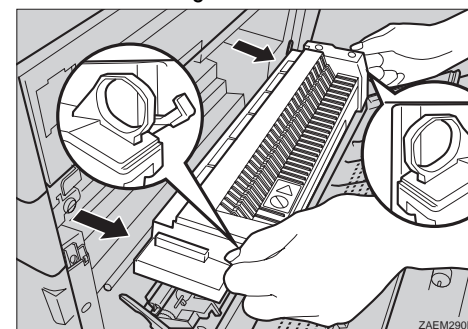

4 Take the new fusing unit from the box and remove the plastic bag.

5 Put the fusing unit removed in step 3 into the plastic bag emptied in step 4.

6 Hold the catches of the new fusing unit with both hands. Keep the unit horizontal. Align the unit onto the rail of the printer and slide the unit into the printer until it stops.

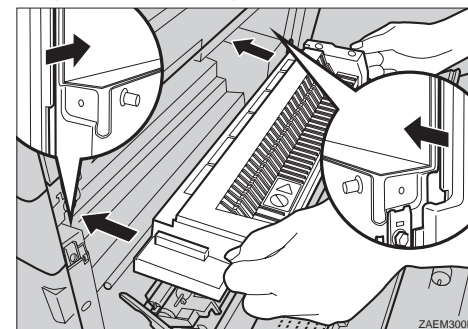

7 Fasten the two screws of the fusing unit.

8 Remove the stopper attached to the red tag.

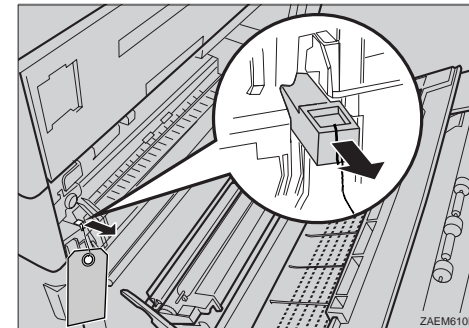

9 Lift the green lever until it stops.

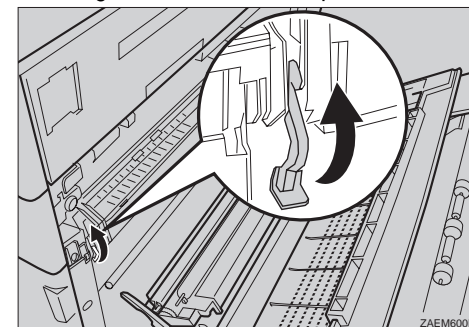

10 Push the place as shown in the illustration to close the right cover of the printer.



11 If the duplex unit is installed, close it.

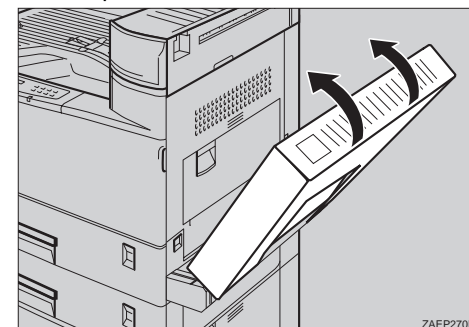

12 Turn on the printer.

Fusing unit replacement is now finished.

Confirm that the message "Replace Maintenance Kit" does not appear on the operation panel.